

Resistors and simple network analysis

Eugeniy E. Mikhailov



WILLIAM & MARY
CHARTERED 1693

Analog Electronics goals

A major portion of an experiment time goes to design, construction, and interfacing different electronic components.

Often, a commercial circuitry is not available or it has to be matched with electronic front-ends (responsible for collecting usually weak signals) or back-ends (which do general purpose processing).

To perform above tasks we need:

- Learn basic discrete components
 - resistors, capacitors, inductors.
 - diodes, photo-diodes, transistors.
 - Op-amps, comparators, logic gates.
- Multimeters, oscilloscopes, function generators.
- Breadboards and soldering irons.
- Modern circuit design and lay-out software.

By the end of the class we will be able to build simple yet capable electronics circuits. Including self-regulating one (i.e. with feedback).

From schematic to the board layout

Schematic

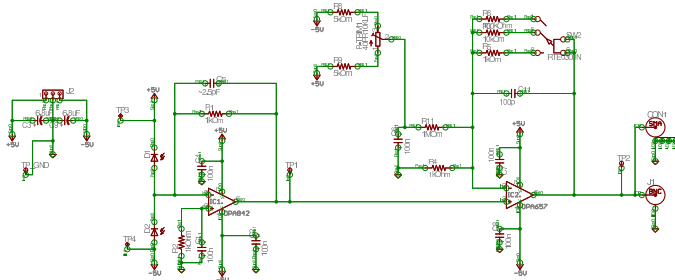

Board layout

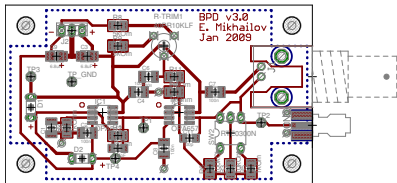

Hardware

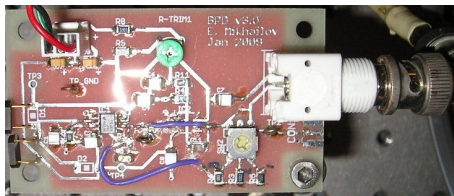

Board development

2009 BPD v3.0

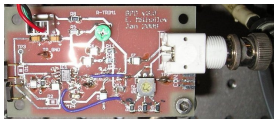

2013 BPD v4.0



2020 BPD ASPECT
v1.12

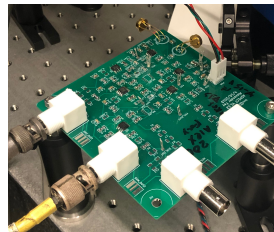

Basic blocks

Voltage (V)

Short for electrical potential difference (voltage drop)

Potential energy divided by charge ($V = E/Q$)

Derived Unit: J/C

SI unit: V (Volt)

Current (I)

Rate of flow of electric charge (dQ/dt)

SI unit: A (Ampere)

Power (P)

Energy per time (dE/dt)

In electronics: $P = VI$

SI unit: W (Watt)

Resistance (R)

Different objects have different current passing through when the same voltage difference is applied.

Which indicates: they have different electrical resistance.

SI unit: Ω (Ohm)

Ohm's law illustrated

Ohm's law

$$I = \frac{V}{R}$$

Ohm's law illustrated

Ohm's law

$$I = \frac{V}{R}$$

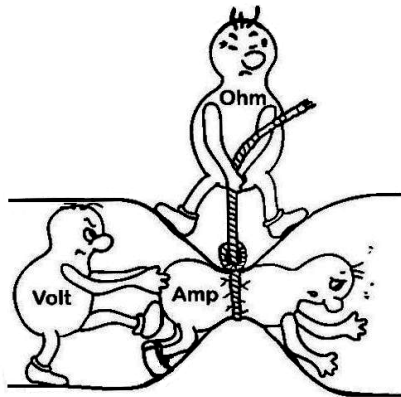

picture taken from www.sengpielaudio.com

Resistors

Standard leaded



1/2 watt



1 watt



2 watt (old style)



2 watt (new style)

Image from
www.audionote.co.uk

Power

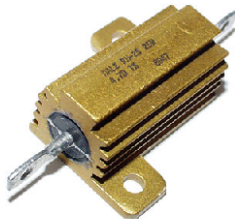

Image from
www.dansdata.com

Surface mounted

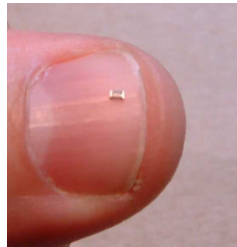
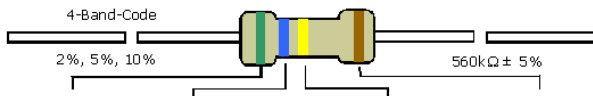

Image from
www.seed-solutions.com

Resistor color code



COLOR	1st BAND	2nd BAND	3rd BAND	MULTIPLIER	TOLERANCE
Black	0	0	0	1Ω	
Brown	1	1	1	10Ω	± 1% (F)
Red	2	2	2	100Ω	± 2% (G)
Orange	3	3	3	1KΩ	
Yellow	4	4	4	10KΩ	
Green	5	5	5	100KΩ	± 0.5% (D)
Blue	6	6	6	1MΩ	± 0.25% (C)
Violet	7	7	7	10MΩ	± 0.10% (B)
Grey	8	8	8		± 0.05%
White	9	9	9		
Gold				0.1	± 5% (J)
Silver				0.01	± 10% (K)



Electronix Express / RSR
<http://www.elexp.com>

1-800-972-2225
In NJ 732-381-8020

Resistors usage

- current limiters
- fix voltage from a current source (exotic use)
- generate heat
- fuse (non standard use)
- lowering the voltage of the source (i.e. voltage dividers)

Unloaded voltage divider

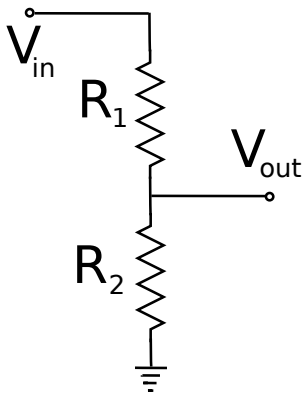

$$V_{out} = V_{in} \frac{R_2}{R_1 + R_2}$$

Loaded voltage divider

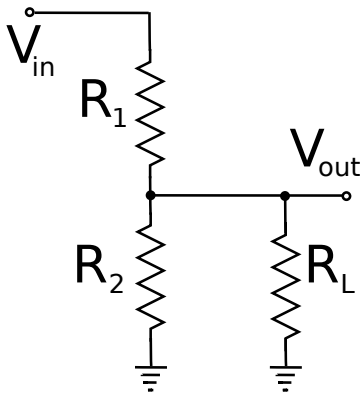

$$V_{out} = V_{in} \frac{R_2}{R_1 + R_2} \frac{R_L}{R_L + R_1 \parallel 2}$$

$$V_{out} = V_{out_{unloaded}} \frac{R_L}{R_L + R_1 \parallel 2}$$

