

Chapter 13: Comparators

So far, we have used op amps in their normal, linear mode, where they follow the op amp Golden Rules (no input current to either input, no voltage difference between the inputs). This week we look at comparators: specialty op-amps which use positive feedback or no feedback.

I. Comparators

Sometimes, you want to use an op-amp in its saturated mode – where the output is pushed either as far positive or as far negative as it can go. This use changes the op-amp from a linear device into a “bistable” device, that is, one that has only two possible output values.

The value of the output is based on a simple decision, made by the chip:

“If $V_+ > V_-$ set the output to the positive rail if not set the output to the negative rail.”

Such a circuit is called a comparator. This is the first step into the world of digital circuits where all output values are expressed as a series of “yes” or “no” answers.

A. Positive Feedback

We often refer to the V_+ voltage as the *reference voltage* and connect the input to V_- . Comparators are supposed to determine:

- If the input (V_-) is less than the reference (V_+) then the output rails high.
- If the input (V_-) is greater than the reference (V_+) then the output rails low.

However, when a comparator looks at a real input signal it will always be faced with some small variations in the signal that make it hard to determine which input is greater. Even worse, this electrical “noise” could drive your comparator through many transitions when you really wanted your signal to show only one transition.

Figure 13.1 shows how a little noise added to a slowly decreasing signal can cause multiple transitions in the output. The top curve shows the comparator output, while the bottom curve shows the V_- input. The dashed line represents the V_+ input.

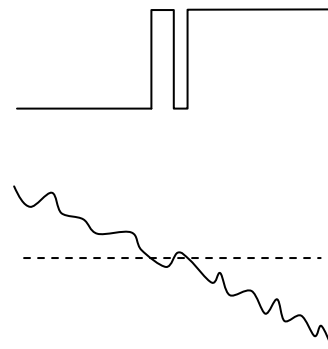

Figure 13.1: A noisy signal on V_- (bottom) generates multiple transitions (top) as it goes above and below the threshold on V_+ (dashed line).

When V_- drops below the threshold (dashed line) the output changes state. When noise makes the input voltage briefly go back above the dashed curve the output “bounces” to low and back to high accordingly.

The solution to this problem is to use positive feedback to simultaneously shift the reference voltage (V_+) as the output changes states. This is illustrated in Figure 13.2. If the shift is large enough, then the output will be less likely to bounce between the two output states during the transition. This shift, which is called a “hysteresis”, depends on the design of the feedback network that ties V_+ to the output level.

An example of how this might work in an op-amp implementation is shown in Figure 13.3. We will start by ignoring the positive feedback, and note that the V_+ input is tied to 0.83 V via a voltage divider formed by a 10 k Ω resistor and a 50 k Ω resistor:

$$V_+ = 5V \frac{10k\Omega}{10k\Omega + 50k\Omega} = 0.83V \quad (13.1)$$

Now let’s consider the effects of the feedback resistor. When the output is high, this places the 100 k Ω resistor (ignore the 4.7 k Ω for now) in parallel with the 50 k Ω resistor so the reference voltage goes up to 1.16 V.

$$V_+ = 5V \frac{10k\Omega}{10k\Omega + 33k\Omega} = 1.16V \quad (13.2)$$

When the output is low the 100 k Ω resistor is now in parallel with the 10 k Ω resistor so the reference voltage goes down to 0.76 V.

$$V_+ = 5V \frac{9k\Omega}{9k\Omega + 50k\Omega} = 0.76V \quad (13.3)$$

Therefore, this circuit’s output will go from high to low when V_- increases beyond 1.16 V. The circuit’s output will go from low to high when V_- decreases below 0.76 V. When V_- is between 0.76 V and 1.16 V, the output will stay at its current value (either high or low). This memory of the past is why this type of feedback effect is called *hysteresis* and is often represented as a plot of output voltage as a function of input voltage. The hysteresis in this case given by

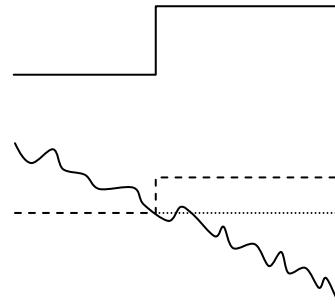

Figure 13.2: When the output makes a transition (top), the reference level can be shifted (dashed) using positive feedback to prevent extra transitions as the input on V_- (bottom) makes multiple transitions across the original reference voltage on V_+ (dotted line).

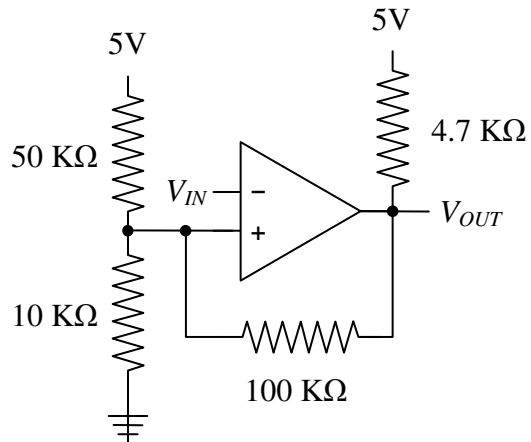

Figure 13.3: Comparator with hysteresis.

$$1.16V - 0.76V = 0.40V \quad (13.4)$$

A plot of the reference voltage (V_{REF}) vs the input voltage (V_{IN}) for a comparator with a positive feedback network (figure 13.4). To make the two parts clear they have been slightly offset vertically. This type of plot is called a *hysteresis plot*. If there is an open box in the middle of the two paths then we say there is an input hysteresis. The hysteresis is defined as the difference between the two values of V_{IN} where there are transitions.

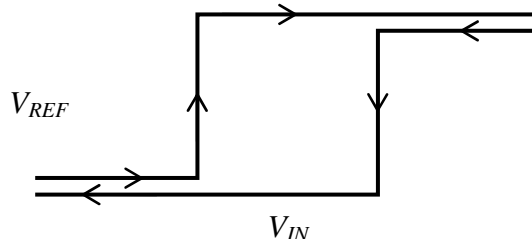

Figure 13.4: A plot of V_{REF} vs V_{IN} for a comparator with a positive feedback network.

This positive feedback circuit is called a *Schmitt trigger*. A slightly better version can be made using two transistors but that's beyond the scope of this chapter.

B. Comparators

Commercial comparators are specialty op amps and come in a standard IC package. They are designed with the sole purpose of switching very quickly and do not have a number of the other good op amp qualities we have been exploiting in negative feedback circuits. The LM2903 and LM311 are the standard comparators that we will use in this week's lab.

Open-Collector Output

Since comparators convert a linear signal into a digital signal, they are routinely used to connect two dissimilar electrical systems with different supply or reference voltages. Consequently, most standard comparators come designed to connect to any system you want to use. The output of a comparator is actually the collector input of a transistor switch (with "open" or "closed" states), rather than actual output voltages – note: in a regular op-amp the output would be some form of push-pull stage.

When you use a comparator in a circuit, you usually connect the output to a voltage source via a *pull-up resistor*, as shown in figure 13.5. When the comparator is in the high state, the switch will be open, no current will flow through the resistor. There will not be a voltage drop across the resistor, and hence the output will be pulled to the positive supply. When the comparator is in the low state, the switch will be closed, current will flow through the resistor. There will be a voltage drop across the resistor, and the output will be pulled to the lower supply level (ground in this case). The 4.7 k Ω resistor in Figure 13.3 is a pull-up resistor.

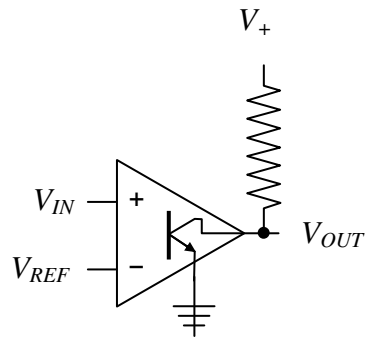

Figure 13.5: Equivalent circuit for an open collector output and a pull-up resistor.

Even though the real open collector states are “open” and “closed,” they are still often called “high” and “low” in the assumption that you are using pull-up resistors.

Comparator Limitations

Comparators typically have high gain at high frequencies and no phase compensation. Since comparators are designed to go all the way from the negative rail to the positive rail during transition, their data sheets list a *transition delay time*, which is the time to go from one rail to the other, instead of a slew rate. For the LM2903 the transition time is roughly 1.5 μs .

The most serious limitation for some comparators is that they will not allow a large voltage difference between V_+ and V_- . This difference is called the *differential input voltage* and should be looked up on the data sheet before you design a circuit using a specific comparator.

Finally, another issue is that the input circuit’s impedance changes as the output state changes.

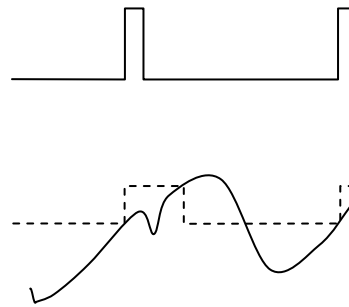

Figure 13.6: The output of the rising edge trigger sends out a pulse (top) when the input (bottom) rises past the threshold (dashed line). The output stays low when the output returns to be low the line. A hysteresis ensures that only one pulse is made per transition even in the presence of noise.

Edge Triggers

A closely related class of circuits is *triggers*. A rising edge trigger will make a *pulse* (fast transition from low to high and back again) each time the input voltage rises past a particular threshold voltage. On the other hand, when the input voltage goes back below the threshold the output stays low. When the output is triggered, the threshold voltage is raised for a certain period of time to prevent multiple triggers. After that time has elapsed, the threshold is lowered back to its normal value. This is called *rearming* the trigger (Figure 13.6).

II. Oscillators

In many electronics applications it is useful to have a small function generator to synchronize various portions of a circuit or to insert time delays between different actions. This is called a *clock signal*.

You should be used to this concept from a trip to a store shopping for PCs. The speed that it will perform individual operations (single core) is proportional to the clock speed. Therefore we know that 3.0 GHz PC will be 10% faster than a 2.7 GHz PC.

One simple way to make a clock signal is using positive feedback and a comparator to make a square wave generator. An example square wave generator is shown in figure 13.7. The circuit is based on a comparator with hysteresis. The comparator is assumed to be powered by 0 V and +5 V. The divider in this example defines the transition levels to be $V_+/3$ and $2V_+/3$.

The wrinkle here is that the output is connected to the reference voltage through an RC circuit. After the output switches state, the capacitor gets charged by the voltage at the output. When the charge on the capacitor gets higher than $2V_+/3$, the hysteresis causes the output to change states and the capacitor gets discharged. When the charge on the capacitor gets lower than $V_+/3$ then the output changes states again. This process repeats forever and the resulting output is a square wave as shown in figure 13.8. The square wave will have the period given by roughly $2\ln(2)RC$.

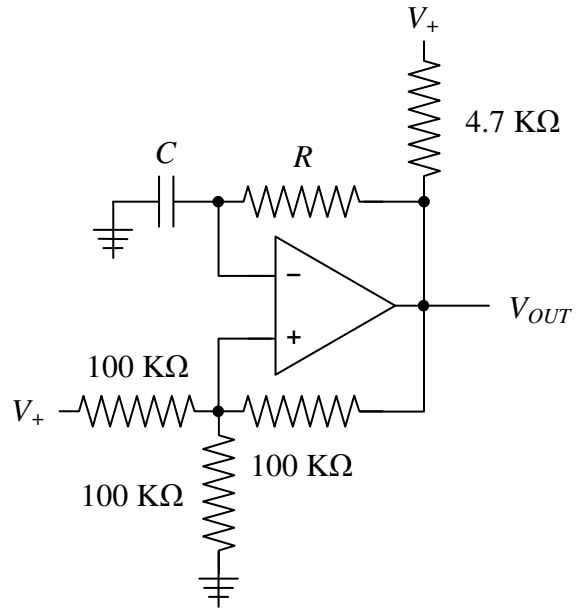

Figure 13.7: A square wave generator made using a relaxation oscillator.

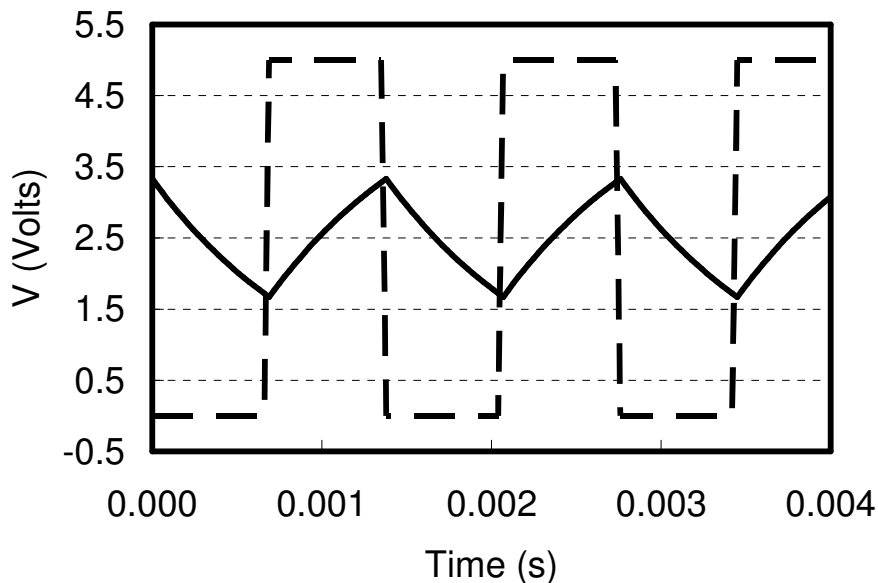

Figure 13.8: The output of the relaxation oscillator shown in Figure 7 (dashed) and the voltage across the capacitor are plotted as a function of time.

Chapter 13: Comparators

These kinds of circuits are called *relaxation oscillators* or *RC oscillator*. They generally work well for frequencies from around 1 kHz to 1 MHz. When designing an oscillator, make sure that R is significantly larger than the pull-up resistor or the output will be asymmetric. (Can you figure out why?)

In precision applications the simple RC oscillator would be replaced by a vibrating crystal. Vibrating crystals are available as precision oscillators with a wide range of frequencies. Suggested designs for using crystals with comparators are available in the data sheets.

Design Exercises

Design Exercise 13-1: Design a comparator that will switch when the input signal crosses +2.5 V with no hysteresis (as in equation 13.1).

Design Exercise 13-2: Modify the design of your comparator with a positive feedback network to add a total hysteresis of approximately 0.2 V.

Design Exercise 13-3: Design a relaxation oscillator with 10 Hz frequency. Use resistor and capacitor values in the same range as those found in the electronics lab.

Bonus: If you run design exercise 13-3 in 5Spice, then you will notice that the square wave is not symmetric (i.e. "high" time is longer than the "low" time). Modify the circuit so that you can make the square wave symmetric.

Lab 13: Comparators and Oscillators

1. Connect a LM2903 comparator to measure where a sine wave crosses +2.5 V, with no feedback. Use +5 V and ground for your supply voltages. Remember that the output must use a “pull-up” resistor. Use a 4.7 K Ω pull up resistor tied to +5 V. Observe and characterize its output when driven by a 1 kHz sine wave with a 1 V amplitude and a DC offset larger than +0.5 V.

Add positive feedback to your comparator to generate a total hysteresis of 0.2 V and observe its effect.

2. Build a square wave oscillator with 10 Hz frequency that drives a green or red LED. Examine the voltage across the capacitor and the output voltage on your scope at the same time to understand the switching structure.

Construction mini-project: You should build the circuit directly onto a prototyping board with all components connected via solder. The webpage has an image of the prototyping board layout. The LED flasher will be powered by a +9 V battery in combination with a +5 V voltage regulator (MC7805, see datasheet for more details). You should use the regulated +5 V output to power your circuit. The regulator guarantees a voltage of +5 V even if the input voltage is not +9 V volts, while also providing additional protection for the rest of the circuit. Also, you should use an IC socket for your LM2903 comparator IC. You may use lab components to construct your circuit.

Bonus points if your prototyping circuit works! ... and you can keep it.

