

Chapter 7: AC Transistor Amplifiers

The transistor amplifiers that we studied in the last chapter have some serious problems for use in AC signals. Their most serious shortcoming is that there is a “dead region” where small signals do not turn on the transistor. So, if your signal is smaller than 0.6 V, or if it is negative, the transistor does not conduct and the amplifier does not work.

Design goals for an AC amplifier

Before moving on to making a better AC amplifier, let's define some useful terms. We define the *output range* to be the range of possible output voltages. We refer to the maximum and minimum output voltages as the *rail voltages* and the *output swing* is the difference between the rail voltages. The *input range* is the range of input voltages that produce outputs which are not at either rail voltage.

Our goal in designing an AC amplifier is to get an input range and output range which is symmetric around zero and ensure that there is not a dead region. To do this we need make sure that the transistor is in conduction for all of our input range. How does this work? We do it by adding an offset voltage to the input to make sure the voltage presented to the transistor's base with no input signal, the resting or *quiescent voltage*, is well above ground. In lab 6, the function generator provided the offset, in this chapter we will show how to design an amplifier which provides its own offset.

Now that you understand capacitors it is pretty easy to see how to add and subtract an offset voltage to a signal, at least for AC signals. From here on, you will design transistor circuits with a bias network. This bias network is simply a voltage divider that is connected to the input. Its job is to insure that the output stays at approximately half the supply voltage for small input signals. Then, the output voltage can vary over a wide range (positive and negative) while always keeping the transistor conducting.

The trick to make this work is to separate these quiescent voltages and currents from the input and output signals. To do this, you will use blocking capacitors to isolate the input and the output. If you connect an AC input to a capacitor, it will not pass any DC offset voltages but it does pass the fast AC signals. Similarly, an output blocking capacitor will pass the fast signal while keeping the quiescent (resting) voltage from the amplifier from disturbing whatever comes next. This is shown schematically in the first figure (next page).

Some Design Basics

This week we are going to redesign our emitter follower and inverting amplifier to use bias networks. To help you with your design, we will make a step by step list for designing each of these basic transistor circuits.

Here are a couple initial design decisions we will make

- You will begin by determining the quiescent (DC, no signal) current through the collector. You usually want the quiescent current to be larger than any current you will use to drive a load. A quiescent current of 1 mA is typical, and we will use that in our example designs.
- We will also use a single +15 V power supply to power the collector (the *common collector voltage* or V_{CC}) for and the bias network.
- We need to be careful about loading the different stages of this amplifier. The transistor's base current will load the output of our bias voltage divider. To bias the base, we need a stiff voltage divider (i.e. low impedance). Our rule of thumb for designing voltage dividers was to have a factor of 10 difference in impedance at each stage.

AC Emitter-Follower

Design steps for the emitter-follower of figure 7.1 proceed as follows:

1. To have the maximum symmetric range of output voltages we would like our quiescent base voltage to be half of the (15 V) supply voltage. So, we will use a 1:1 input voltage divider. This means that both biasing resistors will be the same.

2. We then choose the emitter resistor. The quiescent voltage at the emitter is a diode drop below the voltage in the middle of the bias network (i.e. $V_{cc}/2$ if we have a 1:1 divider). This is roughly +7 V in our case. To get our design quiescent current, the emitter resistor must be

$$R_e = V_e / I_e = 7 \text{ V} / 1 \text{ mA} = 7 \text{ k}\Omega.$$

We will use the standard 6.8 k Ω . It is close enough.

3. To bias the base we want a stiff voltage divider (i.e. low impedance), therefore we want to use resistors that are smaller than the base-emitter-ground impedance ($Z_b = V_b / I_b \sim 750 \text{ k}\Omega$) by a factor of 10 or so. For this example, we will choose two 75 k Ω resistors for this divider.

4. Remember to AC couple (via capacitors) the input and output. The exact values are not particularly important, though you should remember that you are making a biased high-pass RC filter. Values around 0.1 μF are typical if you want $f_{3dB} \sim 20 \text{ Hz}$, but you can use what you have as long as it is not too small.

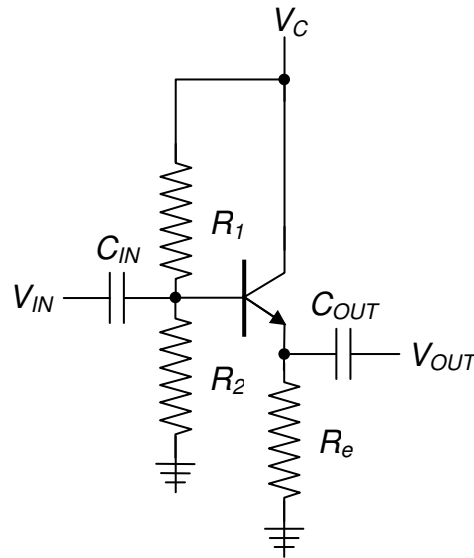

Figure 7.1: A biased emitter-follower *npn* transistor amplifier.

Common-Emitter (Inverting) Amplifier

In this circuit, we need to know the quiescent current and the desired gain. Let's assume a gain of -5 and a 1mA quiescent current for this example. The circuit diagram is shown in figure 7.2.

1. In this circuit we want the quiescent output (at the collector) to be set roughly halfway between the power supply and the ground for maximum output voltage swing. For $I_c = 1 \text{ mA}$,

$$R_c = (V_{cc} - V_c) / I_c \approx 7 \text{ V} / 1 \text{ mA} = 7 \text{ k}\Omega.$$

We will use a standard resistor of about this value (e.g. $R_c = 6.8 \text{ k}\Omega$) as we did for the follower.

2. The emitter resistor can be determined by the desired gain. Previously we saw that

$$\text{Gain} = -R_c / R_e$$

In our case we want a gain of 5 so we chose $R_e = 1.35 \text{ k}\Omega$. We will approximate this by a standard $1.5 \text{ k}\Omega$ resistor. Note that with this choice, the emitter quiescent voltage will be given by the voltage drop across the emitter resistor

$$I_c R_e = 1.5 \text{ V}.$$

3. The tricky part is to design the bias network for this circuit. Since we know the emitter voltage, the output of the bias network (i.e. the base voltage) is just a diode drop higher than the emitter voltage. Therefore the bias resistors must be set to give a base voltage, V_b , of

$$\begin{aligned} V_b = V_2 &= V_e + 0.6 \text{ V} \\ &= 1.5 \text{ V} + 0.6 \text{ V} \\ &= 2.1 \text{ V}. \end{aligned}$$

This is the drop across the lower of the two bias resistors. The other has a drop of

$$\begin{aligned} V_1 &= V_{cc} - V_2 \\ &= 15 \text{ V} - 2.1 \text{ V} \\ &= 12.9 \text{ V} \end{aligned}$$

The bias network's output impedance must be small enough to keep this bias up even when loaded. We will select the bias resistors so that the current running through the bias network is about 10 times larger than the current that goes into the base. If $\beta = 100$, then the base current is

$$I_b = I_c / \beta = 10 \mu\text{A},$$

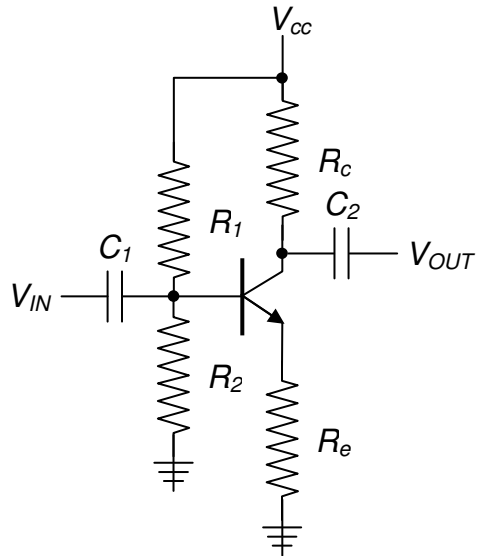

Figure 7.2: A biased *nnp* transistor inverting amplifier.

and the bias current, I_{bias} , is ten times larger: $I_{bias} = 100 \mu\text{A}$. The total resistance of the bias network is $R_1 + R_2$, so we need

$$R_1 + R_2 = (15 \text{ V}) / (100 \mu\text{A}) = 150 \text{ k}\Omega.$$

We can now determine the value for R_2 , since from the voltage divider formula, we require:

$$V_b / V_{cc} = R_2 / (R_1 + R_2) \Rightarrow R_2 = (2.1 \text{ V} / 15 \text{ V}) \cdot (150 \text{ k}\Omega) = 21 \text{ k}\Omega,$$

and therefore,

$$R_1 = 150 \text{ k}\Omega - 21 \text{ k}\Omega = 129 \text{ k}\Omega.$$

4. Remember to AC couple the input and output with capacitors. The values are not particularly important, but the relevant RC time constants should be chosen so as to guarantee unimpeded passage of the AC signal to be amplified.

Design Exercises

Design Exercise 7-1: Design an AC emitter follower with a 1.5 mA quiescent current. Assume that $V_{cc} = 15 \text{ V}$. You can approximate the resistor values by picking the nearest standard values. Assume that Please show any approximations when they are employed.

Design Exercise 7-2: Design an AC inverting amplifier which should operate at frequencies above 100 Hz with a 0.2 mA quiescent current and a gain of 15. Assume that $V_{cc} = 15 \text{ V}$ and $R_L = 1 \text{ M}\Omega$.

Lab 7: Transistor Applications

1. Transistor Switch (30 minutes ... 1 hour)

Construct a voltage controlled transistor switch by connecting the collector of a 2N3904 transistor through a light bulb to a 6 V power supply (see design exercise 6-2). Use a square wave voltage to control the switch. Measure the voltage across the light bulb and compare with your quantitative and qualitative results from lab exercise 4-1 (if necessary repeat lab exercise 4-1).

2. DC-biased AC transistor amplifier (2 hours ... much longer if not prepared)

a. Design and construct a common-emitter amplifier with a quiescent current $I_C = 0.2$ mA, and a gain of ~ 15 at 2 kHz, powered by a +15 V power supply. Measure the small-signal AC gain, and compare it to your calculation. Measure the voltage swing (i.e. the maximum output voltage swing before distortion). Measure the output impedance (Suggestion: use AC coupling).

b. Now try to eliminate the emitter resistor without affecting the DC bias, by using a by-pass capacitor parallel to the emitter resistor. Measure the new small-signal gain. Measure and describe any distortion.

c. Short your emitter resistor to obtain the maximum gain. Measure the new small-signal gain. It will be necessary to change your bias network. Does this agree with your expectations? Measure the new voltage swing. Measure and describe any distortion.

